



Department of Primary Industries

Forestry Investigation Sites-Weirs Design

June 2009

**DRAFT-REPORT**





**THIESS SERVICES, Hydrographic Services - Contact Persons:**

Nurullah Ozbey

Manager Hydrology

Thiess Services

ABN: 69 010 725 247

7 Symes Road

PO Box 96

WOORI YALLOCK 3139

Ph: 03 5949 9421

Fax: 03 5961 5741

Mobile: 0427 529 056

Email: [nozbey@thiess-services.com.au](mailto:nozbey@thiess-services.com.au)

The information contained in this document is solely for the use of the client for the purpose for which it has been prepared. Thiess Services and employees do not guarantee that the publication is without flaw of any kind or is wholly appropriate for your particular purposes and therefore disclaims all liability for any error, loss or other consequence which may arise.

**Document History and Status**

Revision	Date issued	Reviewed by	Approved by	Date Approved	Revision type
Draft Report		N. Ozbey	M Briggs		Draft Report

**Distribution of copies**

Revision	Copy No.	Quantity	Issued to
Draft	1	1	

<b>Printed</b>	
<b>Last saved</b>	9/06/2009 9:16:00 AM
<b>File name</b>	Rpt0217.doc
<b>Author</b>	Nurullah Ozbey
<b>Project manager</b>	Nurullah Ozbey
<b>Name of organisation</b>	Department Of Primary Industries DPI
<b>Name of project</b>	DPI Forestry Investigation Sites
<b>Name of document</b>	DPI Forestry Investigation Sites
<b>Document version</b>	Draft Report
<b>Project number</b>	

**TABLE OF CONTENTS**

<b>1.0</b>	<b>SEDIMENT CONTROL MEASURES .....</b>	<b>1</b>
<b>2.0</b>	<b>FORESTRY INVESTIGATION SITES' DRAWINGS.....</b>	<b>3</b>
2.1	SITE: MIRRANATWA - INVESTIGATION CATCHMENT .....	3
2.2	SITE: MIRRANATWA - CONTROL CATCHMENT.....	8
2.3	SITE: GATUM - INVESTIGATION CATCHMENT .....	10
2.4	SITE: GATUM - CONTROL CATCHMENT.....	11
2.5	SITE: NEST - CONTROL CATCHMENT I .....	12
2.6	SITE: NEST - CONTROL CATCHMENT II .....	15
2.7	SITE: NEST - INVESTIGATION CATCHMENT.....	18

## **1.0 SEDIMENT CONTROL MEASURES**

### **The measures to protect the bed and banks of the waterway and sediment control**

#### **Prepare for work**

All downstream neighbours and river users, such as water authorities, shall be notified of the works.

Everyone involved in the works shall attend a site briefing before starting work.

#### **Minimise sediment disturbance and control erosion**

The works shall be scheduled appropriately which shall be timed to coincide with periods of low flow and completed quickly, and works shall be stopped if conditions are not suitable, such as during and after heavy rain.

Damage to the ground cover shall be minimised and confined to the works site. Blading and grubbing of the banks and the area adjacent to the works site shall be avoided.

Any access tracks shall be minimised. Vegetation on unstable and erodible banks shall be cleared by hand if required. If possible; trees vegetation shall be felled away from the waterway.

The type and size of any heavy machinery and attachments shall be appropriate for the site and the works being done.

All machinery shall be kept out of the waterway on dry and stable areas within the works site.

Existing crossings shall be used to move equipment across the waterway. If there is no crossing and the stream must be crossed, any disturbance shall be minimised.

If crossing once, the machinery shall be carefully 'walked' across the stream. If crossing many times, a temporary crossing shall be made by laying a pad of clean rock at a shallow point of the waterway. The rock shall be removed when works have finished.

When excavating the channel where it is required, the flow shall be diverted and the works site isolated. The stream shall be diverted by constructing a cofferdam using sandbags, clean rock, steel sheeting or other non-erodible material.

Boulders, rock, shingle, gravels, soil and vegetation from the stream bed and banks shall not be used or removed without consultation.

Excavated material shall be placed well away from the waterway to minimise erosion back into the stream. Fill shall not be pushed into the waterway or stored in flood-prone areas.

#### **Avoid contaminant spills**

All workers have been trained and equipped to contain equipment spills and leaks.

If a spill occurs, immediate steps shall be taken to stop it polluting the water, including the ground water. The spill shall be reported to the appropriate authorities as soon as possible.

Petroleum products and other hazardous substances shall be kept out of the waterway.

Refuelling, top-ups and oil checks shall be done well away from the waterway. Fuel and servicing and refuelling equipment shall be stored so the fluids cannot enter the waterway. Keep machinery off wet and unstable areas.

Dirt and mud shall be removed from all equipment before entering the works site and waterway to avoid transferring weeds and disease. Wash-down water is not to enter the stream.

Fresh concrete shall be kept out of the waterway.

Paints shall not be allowed to enter the waterway when constructing, repairing and maintaining in-stream structures.

When using wood treated with preservatives, the chemicals shall be given enough time to fix before immersing the wood in the water.

#### **Stabilise and rehabilitate banks**

The site shall be rehabilitated when the works have finished. Native vegetation shall be established on all exposed soil surfaces,

#### **Further measures to be taken to have maximum benefit from the study with as little impact as on the environment**

Weir will be designed as low as possible to reduce the impact of water speed on downstream reach and the size of pool formed at upstream while it still provides free-fall flowing condition hence the accuracy of the data shall not be compromised due to backwater effect from downstream reach,

Concrete wing walls shall be installed around the weir plate to provide stability for whole structure and to prevent leakage hence low flow can be captured accurately without any leakage's impact on data,

Marine Ply shall be wrapped with plastic lining and sealed with concrete in the ground to prevent leakage under the weir. Once the study is completed, the weirs made from Marine Ply can be removed easily to assist the creek to return in its natural conditions.

Rock chute downstream and rock beaching on the banks upstream and downstream of weirs shall be installed to dissipate water speed to prevent erosion along the reach and provide stability for the structure.

## 2.0 FORESTRY INVESTIGATION SITES' DRAWINGS

### 2.1 SITE: MIRRANATWA - INVESTIGATION CATCHMENT

The creek bed erosion was observed at downstream of proposed weir location during the inspection, signifying unstable bed formation and may cause further instability for the weir. In order to prevent leakage around or under the weir, and to add stability, the weir shall be supported by wing-walls. Rock beaching is to be placed against the banks of the creek as illustrated in Figure 3 to prevent erosion and to provide further stability for the structure.

**Figure 1- Location of proposed weir**



Figure 2 - Proposed Weir Layout



Figure 3 - Plan View

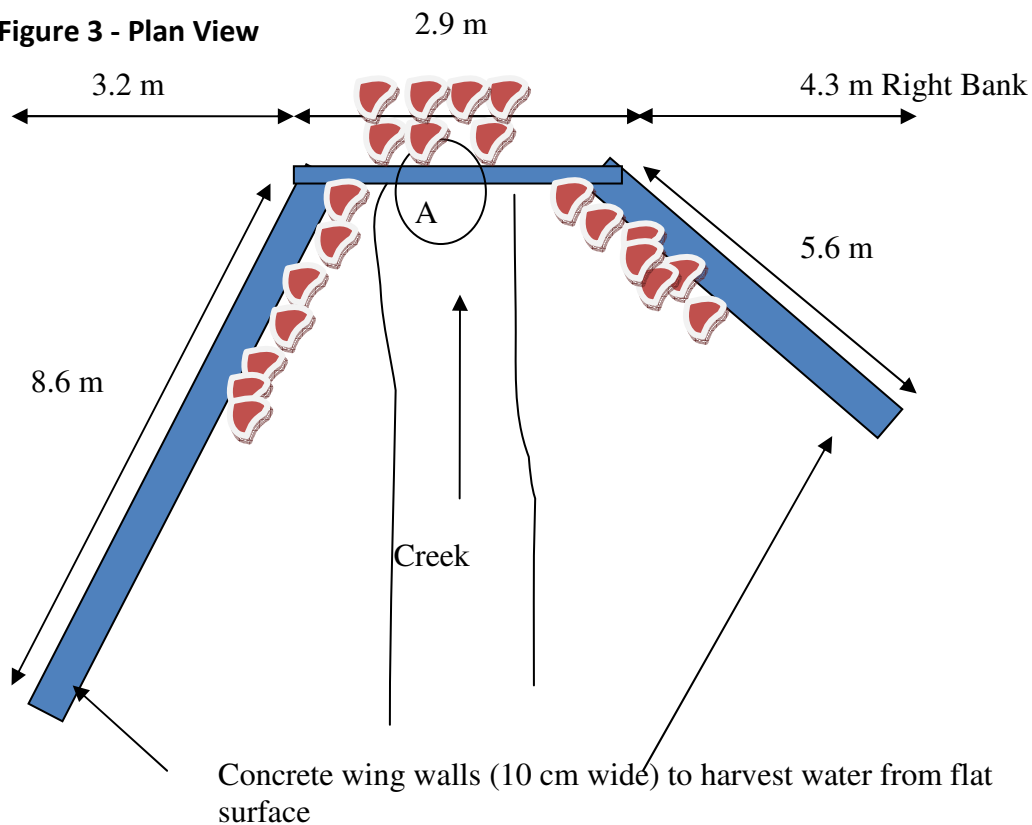

Section A

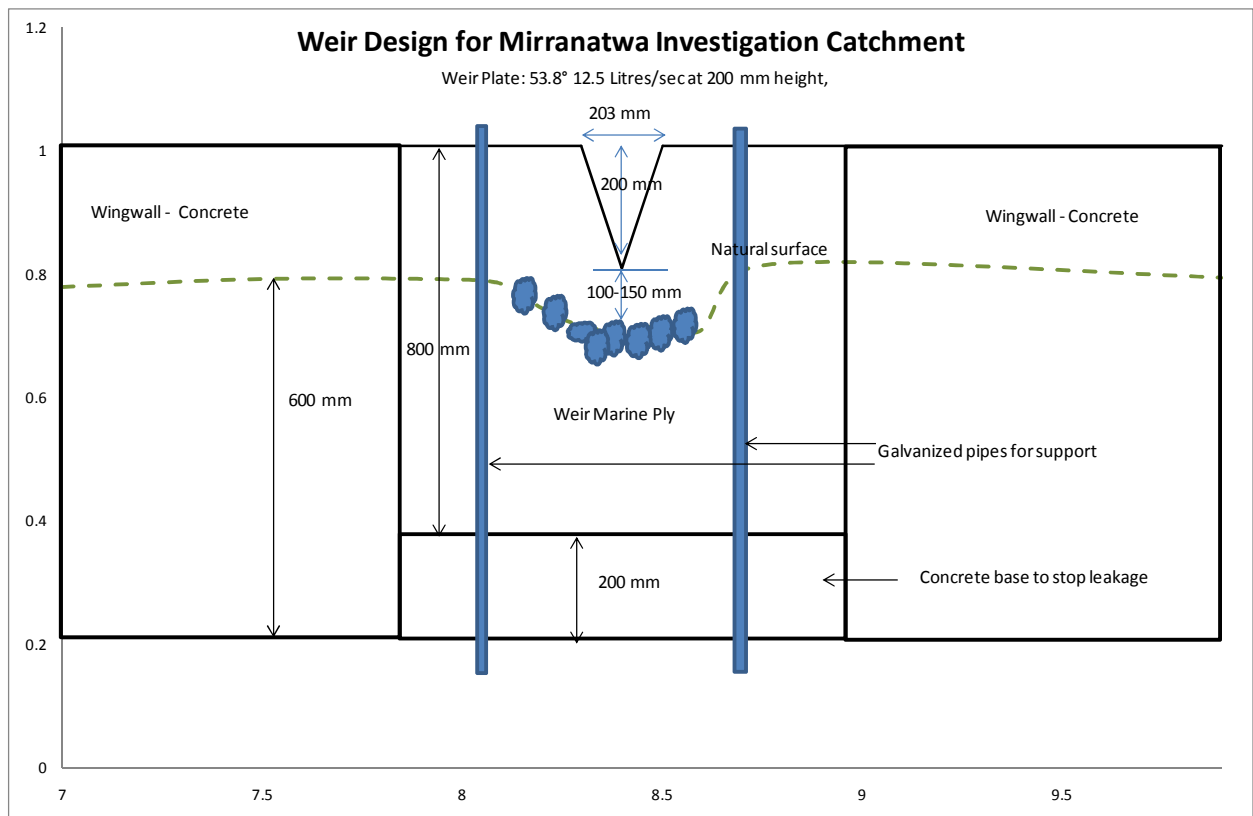

Knife edge is stainless steel and the weir itself is made from Marine Ply.

Figure 4 - Front View - looking upstream from downstream

Right Bank

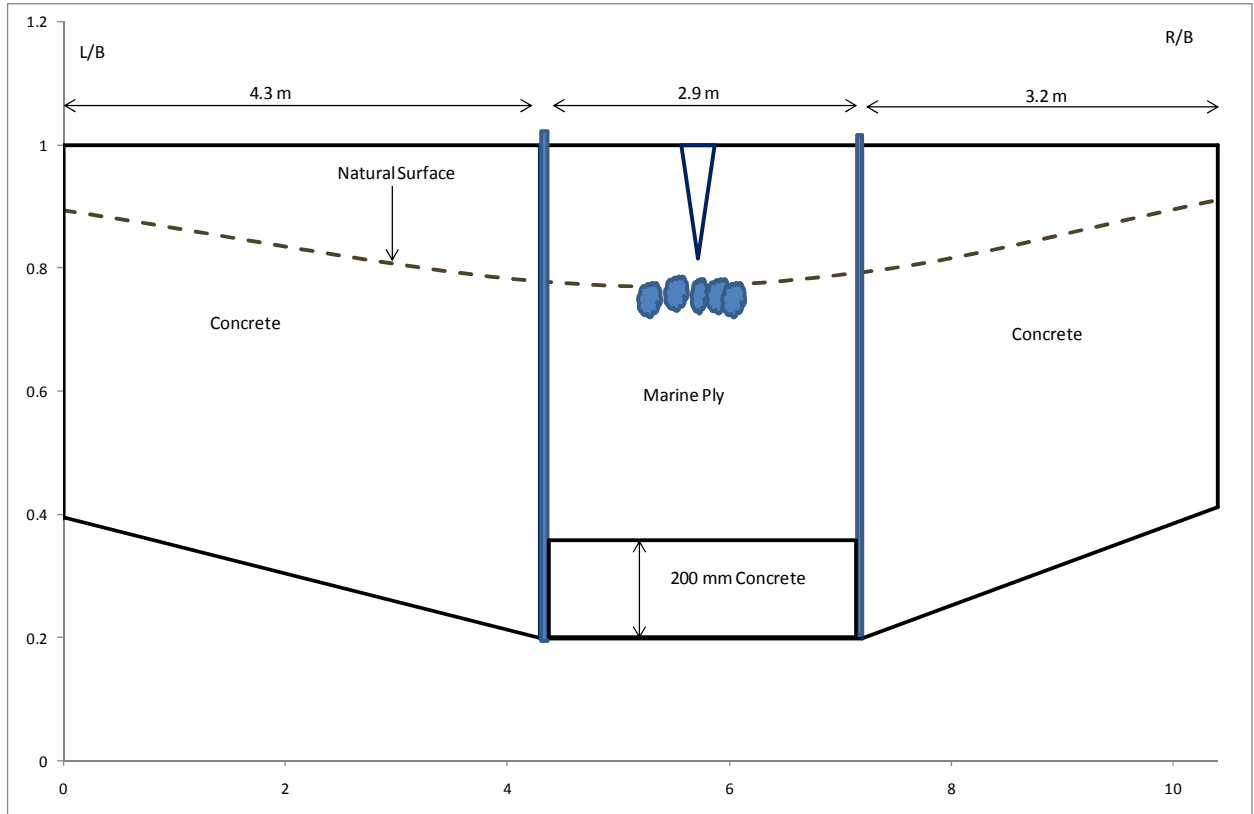
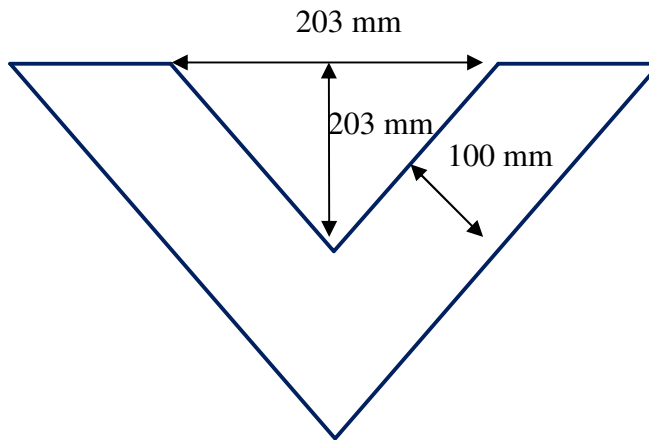

Figure 5 - Sample for a weir to be built



Figure 6- Weir plate dimension-Stainless Steel



Details of crest and sides of V notch for all sites

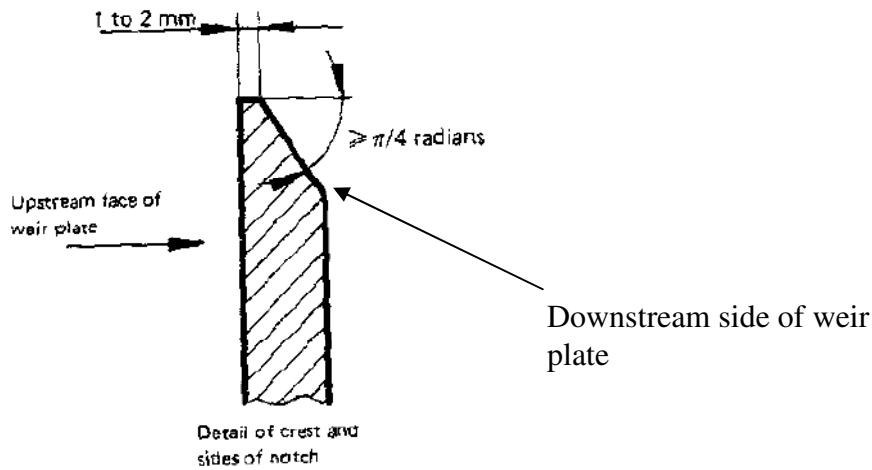

2.2 SITE: MIRRANATWA - CONTROL CATCHMENT

Figure 7- Location of the proposed weir



Figure 8 Front View - looking upstream from downstream

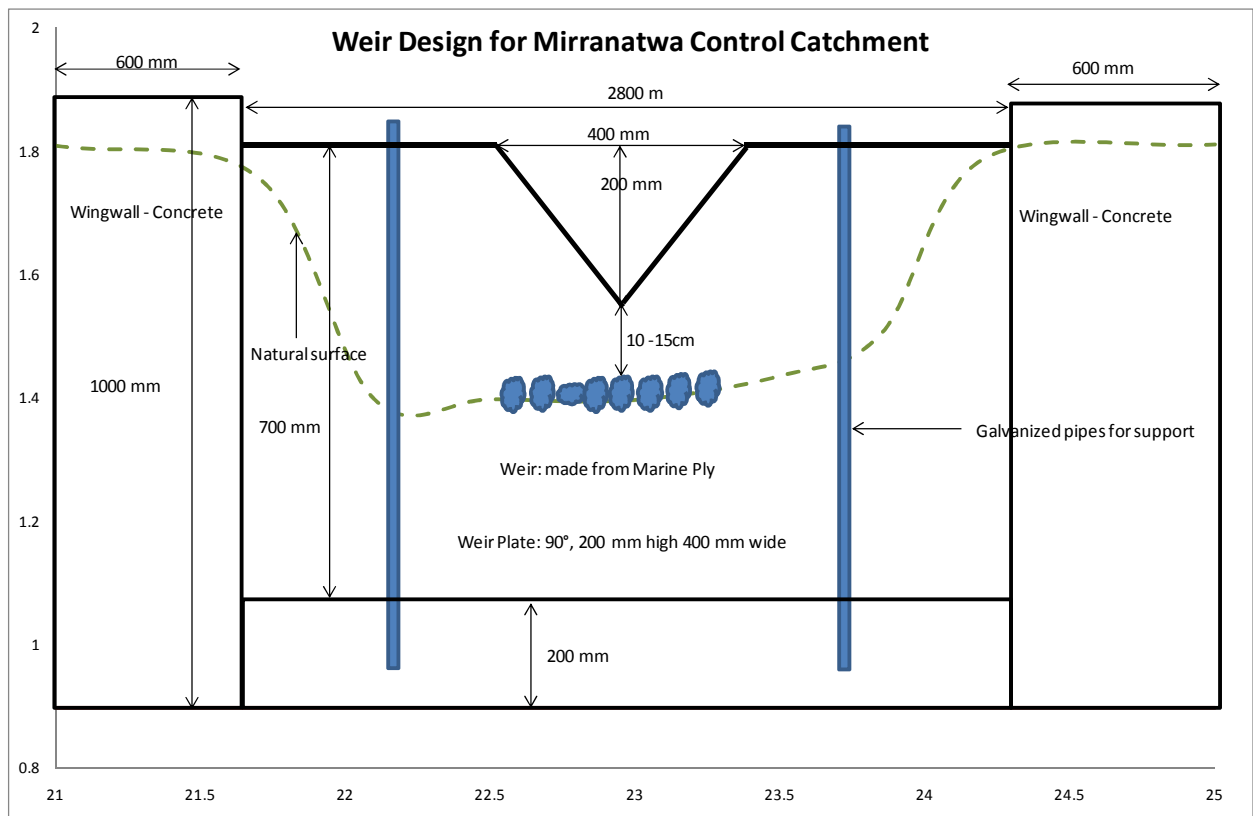
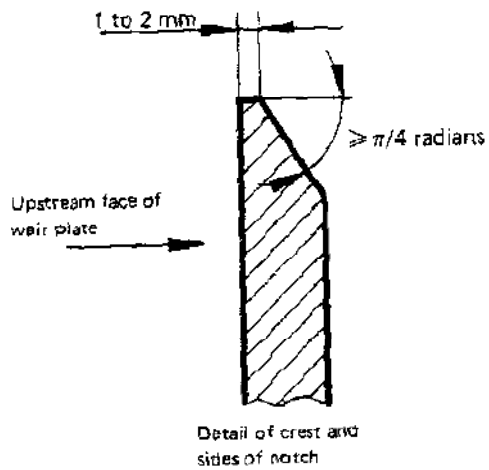
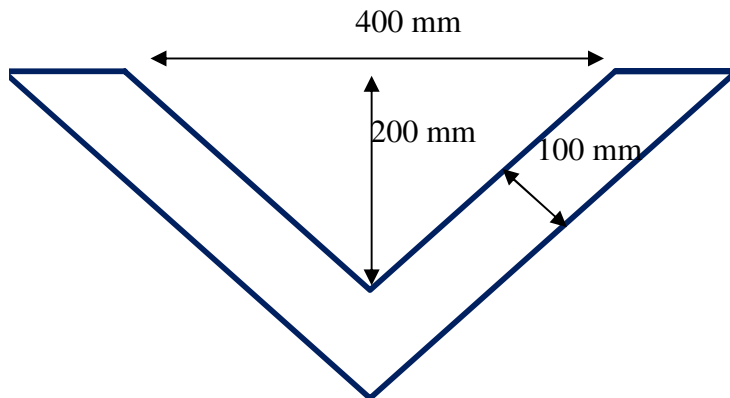
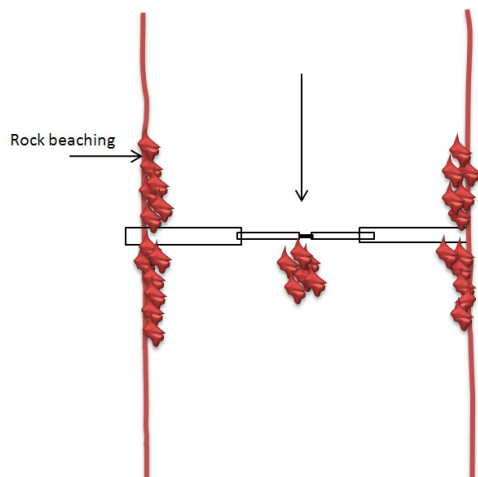

Figure 9 - Weir plate dimension-Stainless Steel



Rock beaching is to be placed against the banks of the creek as illustrated below to prevent erosion and to provide stability for the structure. Concrete wing walls will be 10 cm wide.

Figure 10 – Rock beaching around the structure



### 2.3 SITE: GATUM - INVESTIGATION CATCHMENT

Existing broad crested weir U/S of road is to be rated. No construction for a weir is required.

**Figure 11 - Broad Crested Weir at U/S of Road**



#### Tasks

- 1) The crest of broad crested weir is to be paved (edges are not to be rounded) to improve the accuracy of rating table, –THIESS Hamilton
- 2) The pool behind the weir is to be cleaned, –THIESS Hamilton
- 3) The right bank on the edge of concrete is to be blocked for accuracy, -THIESS Hamilton
- 4) The rating table and accuracy statement will be developed after the gauge board is installed and the survey is conducted to tide the crest level to the gauge datum.

## 2.4 SITE: GATUM - CONTROL CATCHMENT

The existing V notch weir plate U/S was corroded. The weir plate is to be built and installed at existing infrastructure. Inlet pipe of stilling well also is to be extended.

Figure 12 - Existing Weir



2.5 SITE: NEST - CONTROL CATCHMENT I

Figure 13 – Location of Proposed Weir



Figure 14 - Proposed Weir

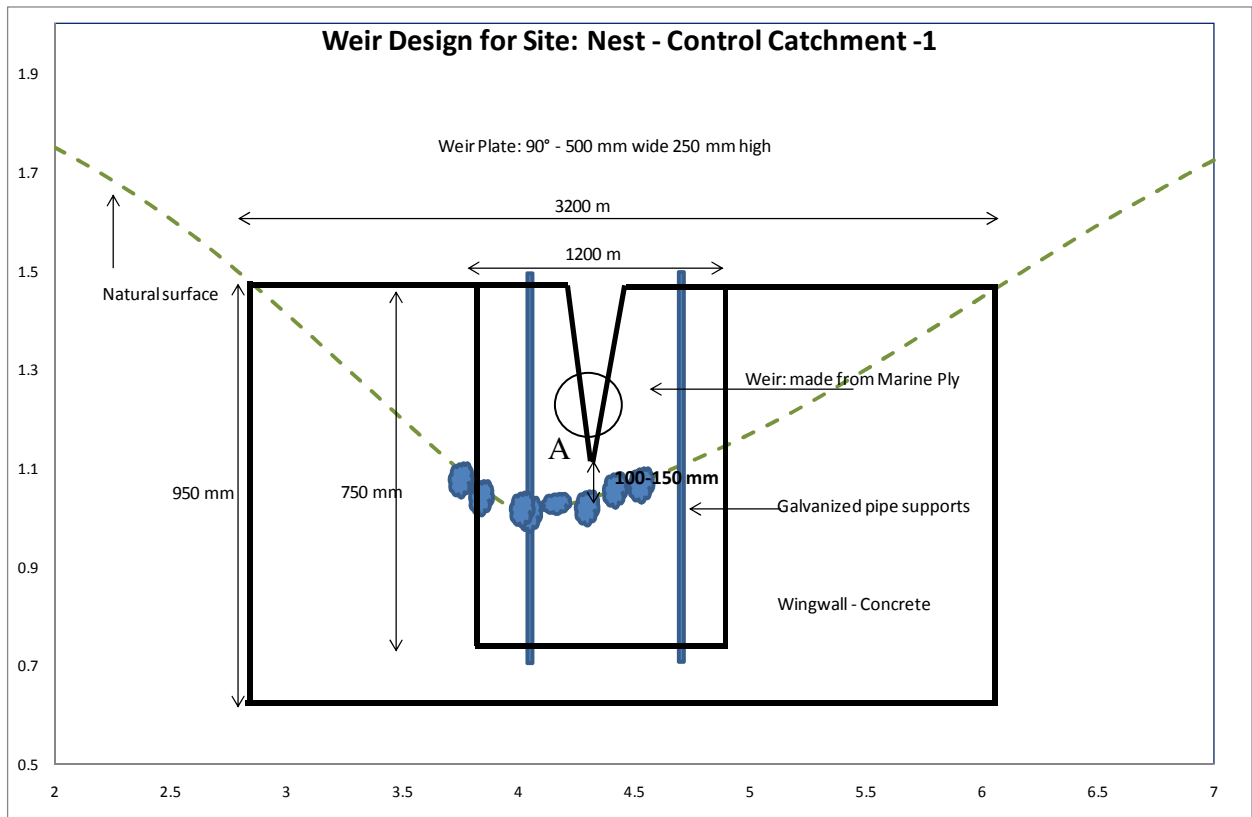

Section A

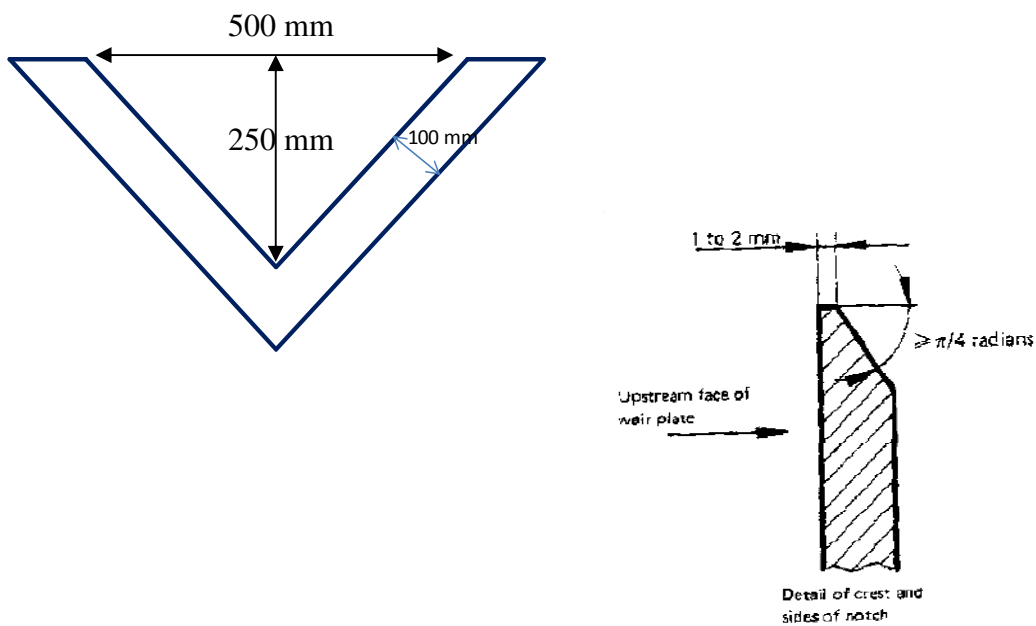

Rock beaching is to be placed against the banks of the creek as illustrated below to prevent erosion and to provide stability for the structure. Concrete wing walls will be 10 cm wide.

**Figure 15 Rock beaching around the structure**

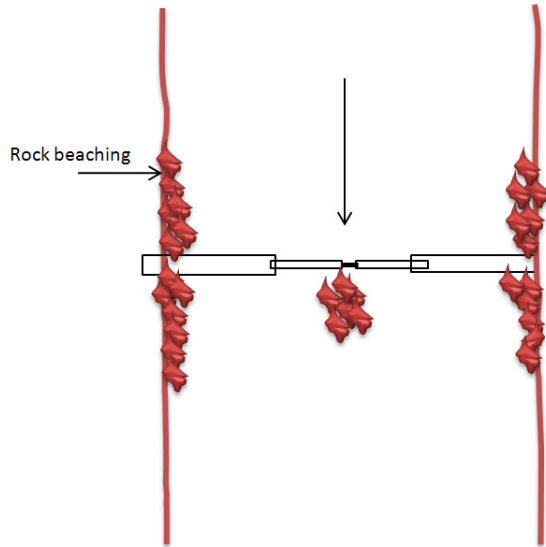

2.6 SITE: NEST - CONTROL CATCHMENT II

Figure 16 –Location of proposed weir





Rock beaching is to be placed against the banks of the creek as illustrated below to prevent erosion and to provide stability for the structure. Concrete wing walls will be 10 cm wide.

**Figure 18 Rock beaching around the structure**

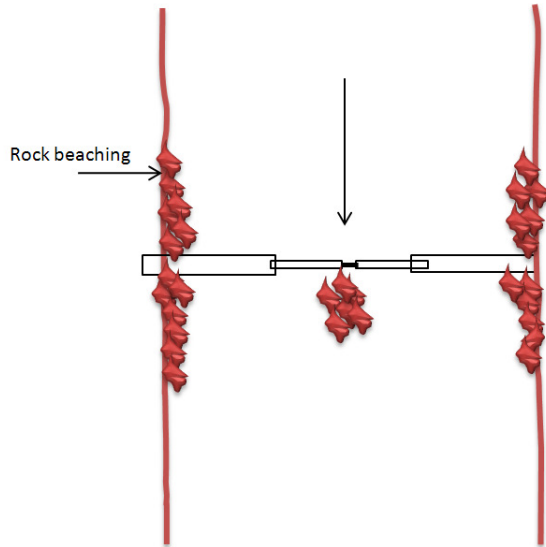

2.7 SITE: NEST - INVESTIGATION CATCHMENT

Figure 19 – Location of proposed weir



Figure 20 - Proposed Weir

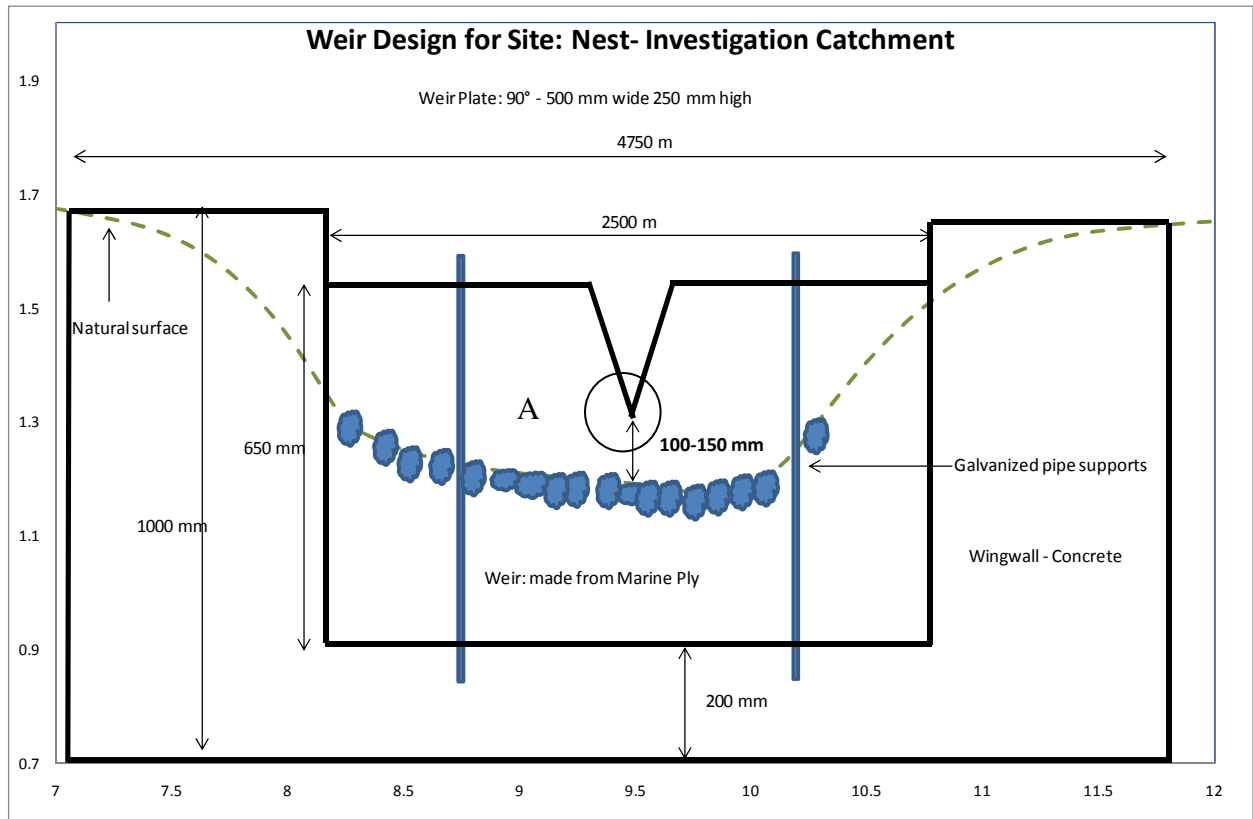

**Section A**

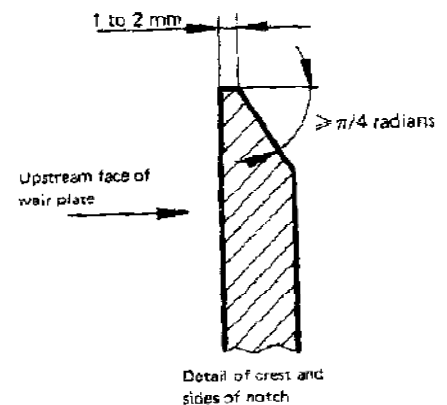
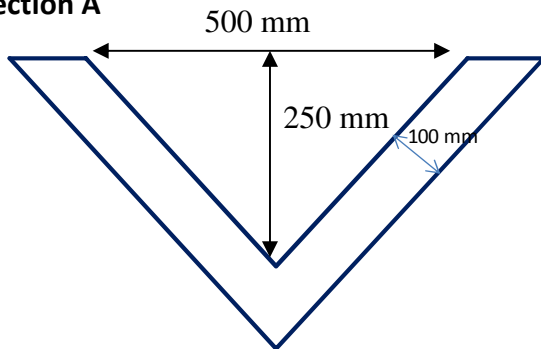

Rock beaching is to be placed against the banks of the creek as illustrated below to prevent erosion and to provide stability for the structure. Concrete wing walls will be 10 cm wide.

**Figure 21 Rock beaching around the structure**

